

2019 Civil Aviation Symposium

The Future of Civil Aviation in the Asia Pacific Region

Shuichi Fujimura

ANA

8th October, 2019

Hub & Spoke Partnership/Codeshare

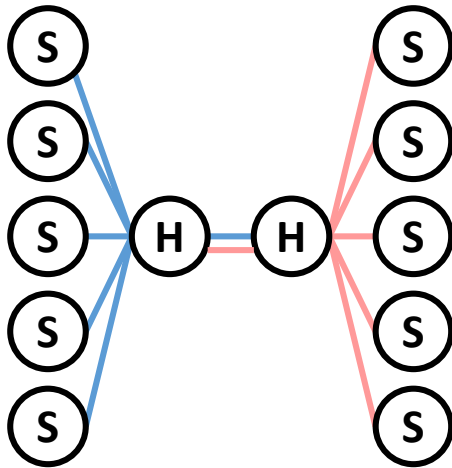

"Fragmentation"

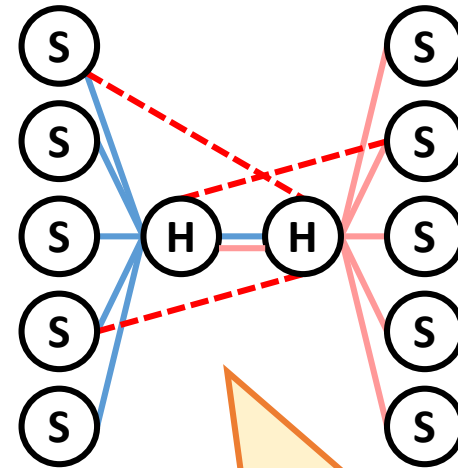

New types of aircraft
(B787, A350 etc...)

- Range ↑
- Capacity ↓

e.g.)

- ANA NRT=MEX,SJC (B787)
- UA SFO=SIN (B787)
- PR MNL=JFK (A350) /LAX/SFO (B777)
- SQ SIN=EWR/LAX/SFO/SEA (A350)

Bilateral JVs

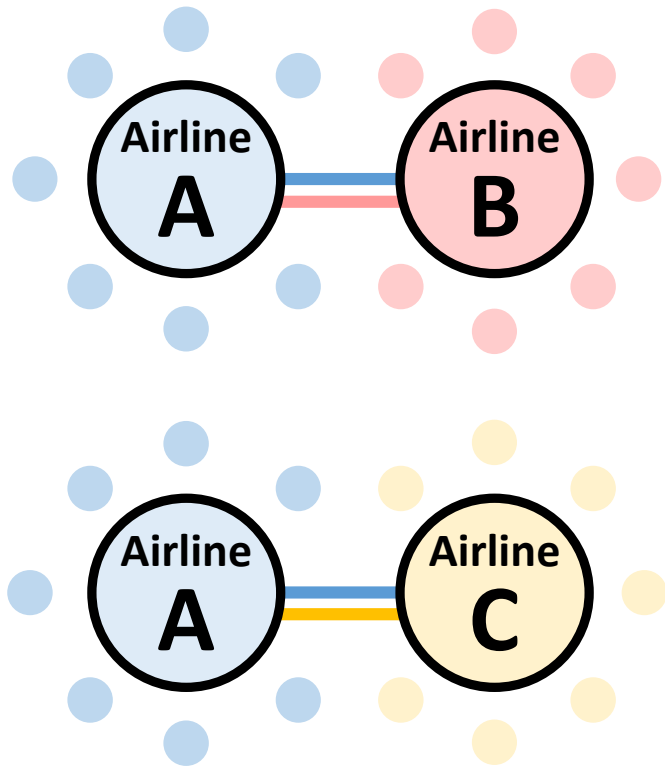

Multilateral JV

